



# FLOMAX 15 HYDRAULIC

## 3" X 3" Self Priming Centrifugal Pump

FLOMAX® 15 hydraulic self-priming centrifugal pumps are capable of creating vacuum sufficient to lift liquids from heights up to 25 feet above the source. Once primed, the pump's built in flapper valve will maintain a full column of liquid in the suction line.

A FLOMAX® 15 hydraulic pump is available with a .73 cubic inch displacement gear motor with hydraulic flows ranging from 8 GPM to 15 GPM and hydraulic pressures ranging from 500 PSI to 1700 PSI.

Standard features include stainless steel drive sleeve, stainless steel fasteners, renewable wear plate, and a semi-open dynamically balanced impeller. Options include double grease lubricated seals, stainless steel impeller and seals for all types of abrasive and/or corrosive services.

The FLOMAX® series of pumps are commonly used in Industrial, Agricultural and Marine applications, such as: Bilge Pumps, Auxiliary Fire Pumps, Ballast Transfer Pumps, Washdown Pumps, Fertilizer and Pesticide Pumps, Applicators & Sprayers, Blending Pumps, Nurse Tanks, Bulk Transfer Pumps and much more.

### SPECIFICATIONS:

Suction And Discharge	3" x 3" NPT
Materials Of Construction	316 stainless steel, Bronze, Cast iron
Flow	Up to 318 GPM
Head Feet	Up to 183'
Drive Options	Hydraulic motor .73 cu. in.
Seal	Special seal material combinations available (consult factory), Standard carbon / ceramic / Viton
Psi	Up to 82
Hydraulic Fluid Flow	Up to 15 GPM
Hydraulic System Pressure	Up to 1700 psi
Max Solid Size	.625" diameter
Hydraulic Motor	Gear
Options	Hydraulic motors with flow control

#### Application

- Agricultural
- Industrial
- Marine

#### Features

- Renewable wear plate
- Stainless steel drive sleeve
- Stainless steel fasteners
- Up to a 25' suction lift

# FLOMAX 15 HYDRAULIC

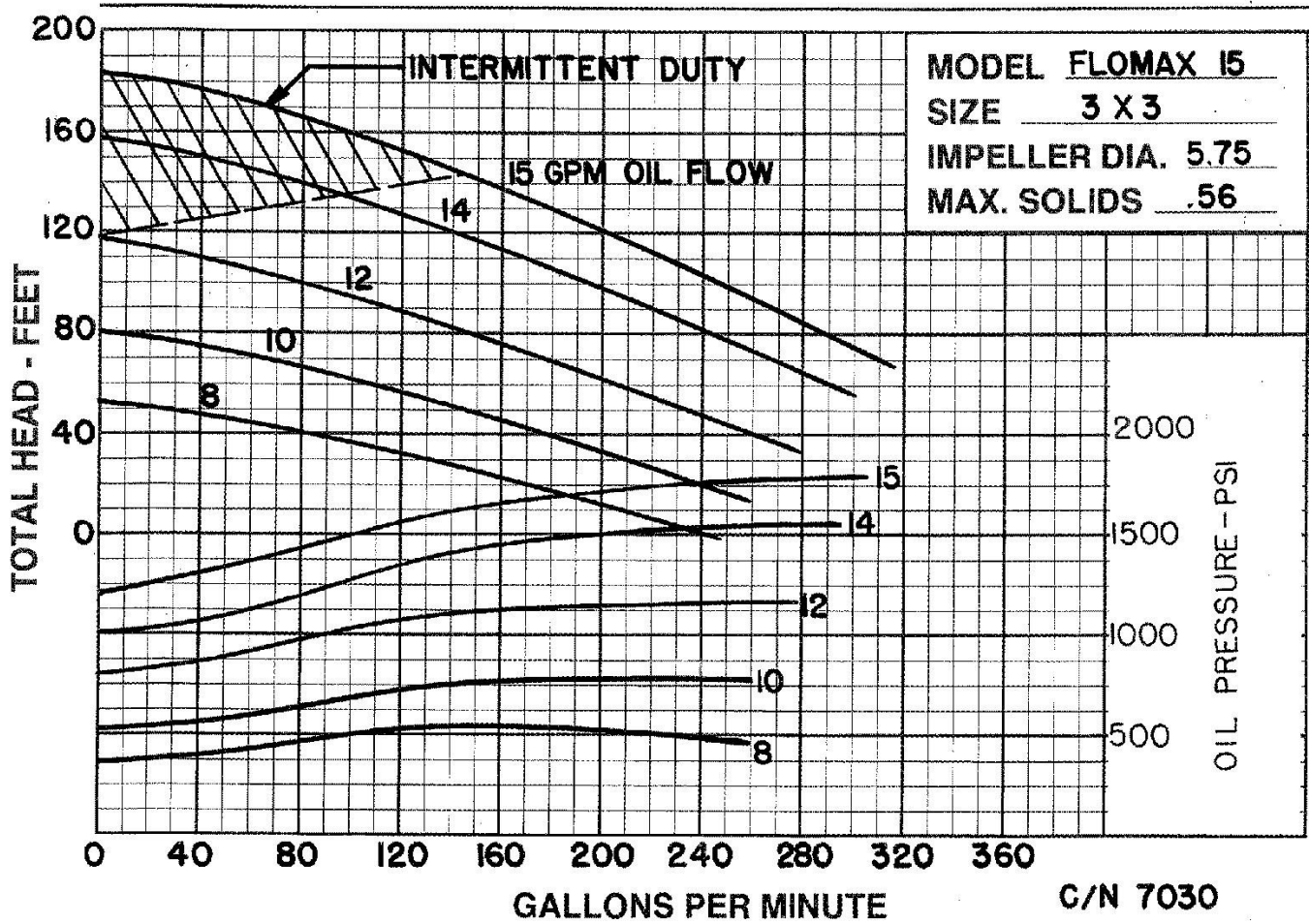

34800 BENNETT - FRASER, MI 48026-1686  
 (586) 293-8240 - FAX (586) 293-8469  
 (800) 563-8006 - www.mppumps.com



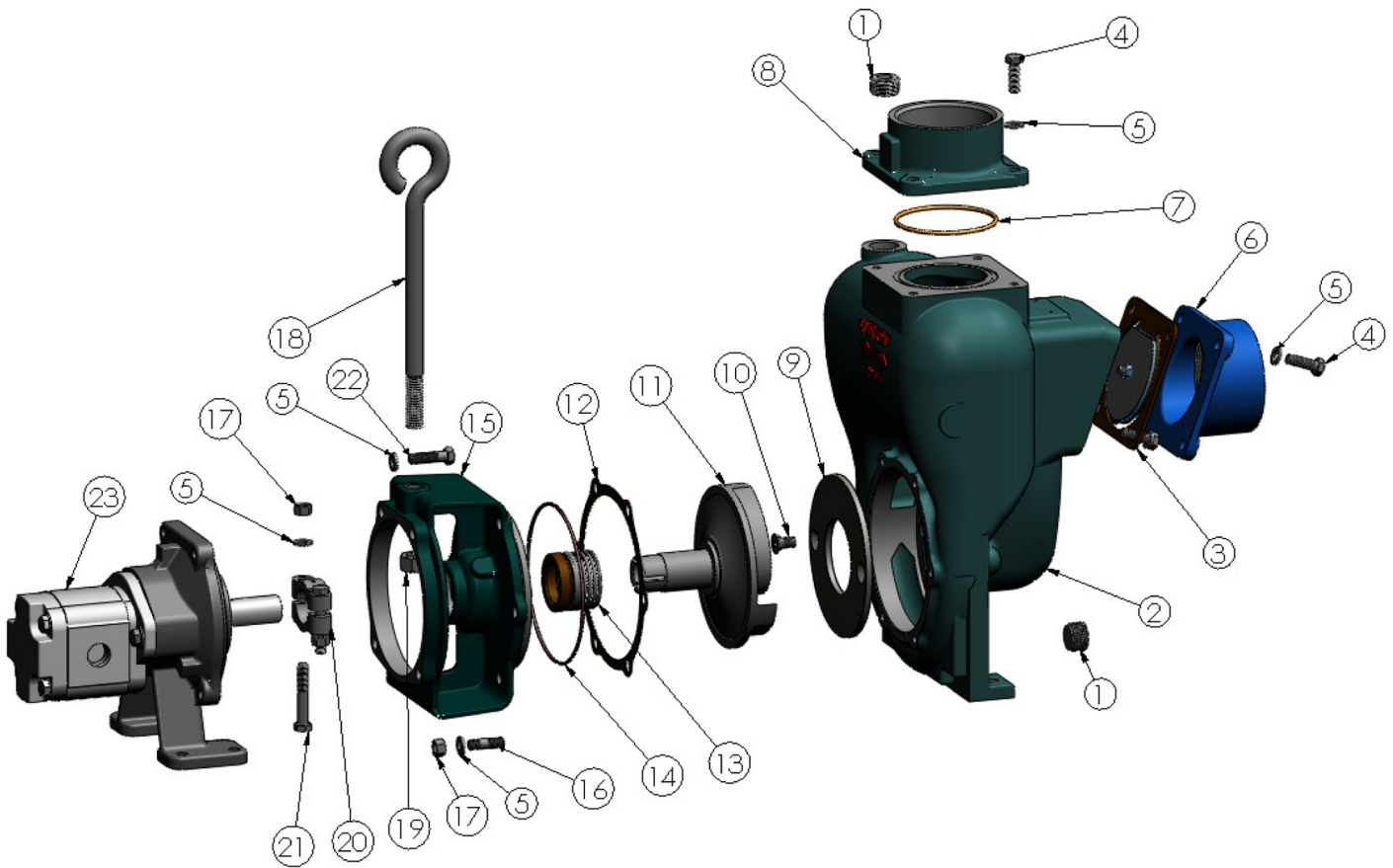

ITEM NO.	PART NO.	DESCRIPTION	QTY.		ITEM NO.	PART NO.	DESCRIPTION	QTY.
1	41481	PIPE PLUG C.I. - 3/4" NPT	2	*	12	22240	GASKET .O32 - NI-2085	1
2	22351	HOUSING C.I.	1	*	13	22361	SEAL ASSY 1.5 TYPE 21 - VITON	1
3	23040	FLAPPER ASSY. BUNA	1	*	14	29715	O RING - VITON	1
4	21291	CAPSCREW S.S. - 3/8-16 X 1.13	8		15	22348	ADAPTER C.I.	1
5	21266	LOCKWASHER S.S. - 3/8	20		16	21260	STUD 3/8-16 X 1.32 S.S.	6
6	22468	SUCTION FLANGE - C.I.	1		17	21268	HEXNUT S.S. - 3/8-16	8
7	37138	O RING - VITON	1		18	22460	LIFTEYE ZPS. - 5/8-11 X 10"	1
8	22471	DISCHARGE FLANGE - C.I.	1		19	22461	HEXNUT STL. - 5/8-11	1
9	22244	WEAR PLATE STL.	1		20	22356	CLAMP S.S. - 1"	2
10	37115	FLAT HD SCREW S.S. - 3/8-16	2		21	21269	CAPSCREW S.S. - 3/8-16 X 2.25	2
11	24721	IMPELLER SS - 5.75 DIA.	1		22	21259	CAPSCREW S.S. - 3/8-16 X 1.38	4
					23	28551	PEDESTAL ASSY. - ULTRA	1

\*RECOMMENDED REPLACEMENT PARTS