

SERIES 30 60 80 110

END SUCTION CENTRIFUGAL PUMP FEATURES

- SERIES 30, 60, 80, 110, 120, 130, 200, 300 & 700 CLOSED COUPLED TO ELECTRIC MOTOR
SERIES 300 PEDESTAL PUMP, OR FOOT MOUNTED FOR BELT OR DIRECT DRIVE
SERIES 700 PEDESTAL PUMP FOR BELT OR DIRECT DRIVE

- PUMPAK ONLY TO MOUNT TO STANDARD NEMA "C" FACE MOTOR .3-40 HP

- NEMA JP PUMP MOTOR UP TO 25HP

- FLOWS - 40-800 GPM

- PRESSURES - 40-190 FEET HEAD

AVAILABLE IN:

- SERIES 30 CAST IRON, BRONZE CONSTRUCTION
- SERIES 60 CAST IRON
- SERIES 80, 110, 120, 130 & 200 CAST IRON & BRONZE
- SERIES 300 CAST IRON AND CAST IRON STAINLESS STEEL FITTED
- SERIES 700 DUCTILE IRON CONSTRUCTION

- VERTICAL OR HORIZONTAL DISCHARGE

IMPELLER:

- SERIES 30 AVAILABLE IN CAST IRON, BRONZE
- SERIES 60, 110, 130 AND 200 AVAILABLE IN CAST IRON & BRONZE
- SERIES 80 & 120 AVAILABLE IN BRONZE (CAST IRON OPTIONAL)
- SERIES 300 & 700 AVAILABLE IN DUCTILE IRON-ENCLOSED

SHAFT SLEEVE:

- SERIES 30, 60, 80, 110, 130 & 200 STAINLESS STEEL
- SERIES 300 STEEL
- SERIES 700 STEEL OR STAINLESS STEEL

- FASTENERS - STAINLESS STEEL

- SEALS - STANDARD VITON, OPTIONAL SEALS AVAILABLE (CONSULT FACTORY)

OPTIONS:

- ENGINE DRIVES
- PEDESTAL MODELS
- HYDRAULIC DRIVES
- CLUTCHPAKS
- MOTOR DRIVES

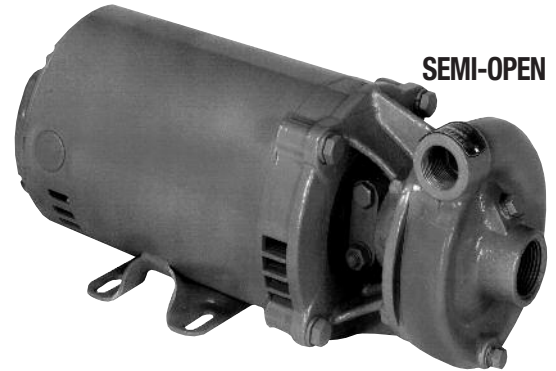

SEMI-OPEN

SERIES 30

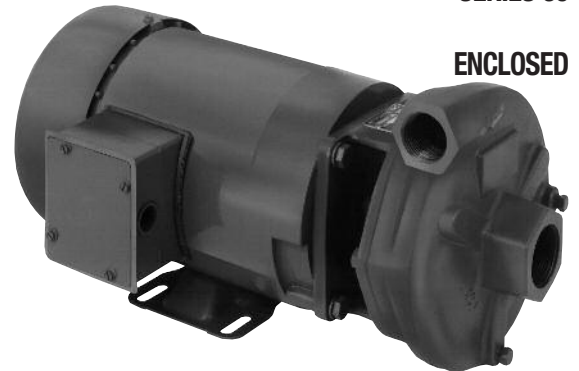

ENCLOSED

SERIES 60



ENCLOSED

SERIES 80



SEMI-OPEN

SERIES 110

120 130 200 300 700

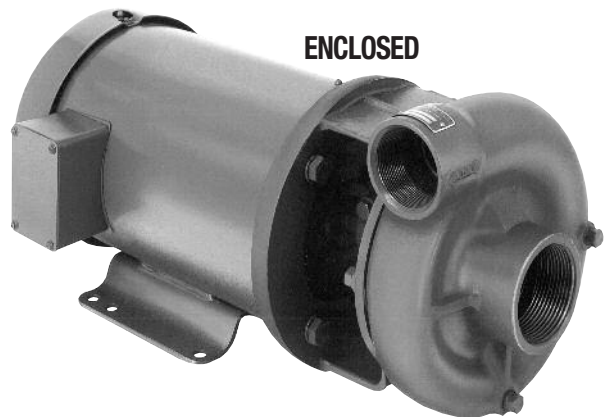

ENCLOSED

SERIES 120

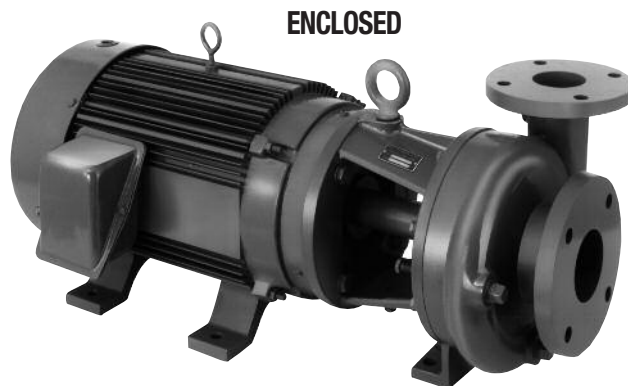

ENCLOSED

SERIES 300



SEMI-OPEN

SERIES 130

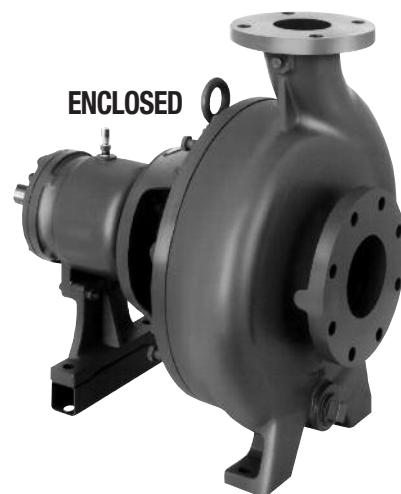

ENCLOSED

SERIES 700

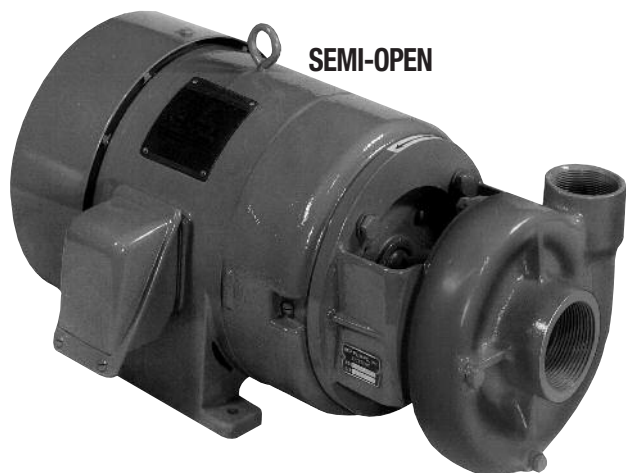

SEMI-OPEN

SERIES 200

MODEL	Suction	Discharge
SERIES 30	1" NPT	3/4" NPT
SERIES 60	1 1/4" NPT	1" NPT
SERIES 80	1 1/2" NPT	1 1/4" NPT
SERIES 110	1 1/2" NPT	1 1/4" NPT
SERIES 120	2" NPT	1 1/2" NPT
SERIES 130	2" NPT	1 1/2" NPT
SERIES 200	2 1/2" NPT	2" NPT
SERIES 300	3" ANSI Flange	2 1/2" ANSI Flange
SERIES 700	4" ANSI Flange	3" ANSI Flange

Series 30 Pump Performance Curves

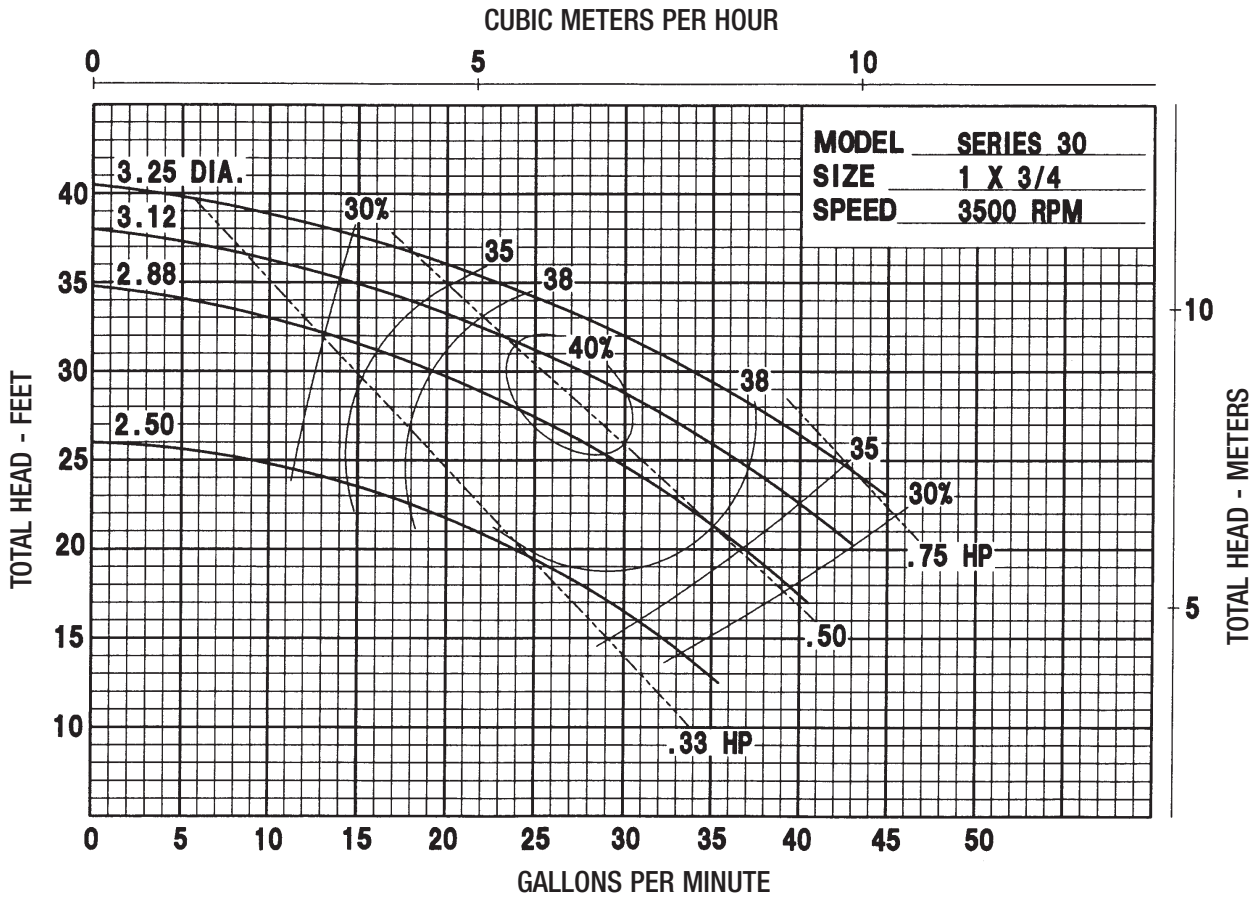

Series 60 Pump Performance Curves

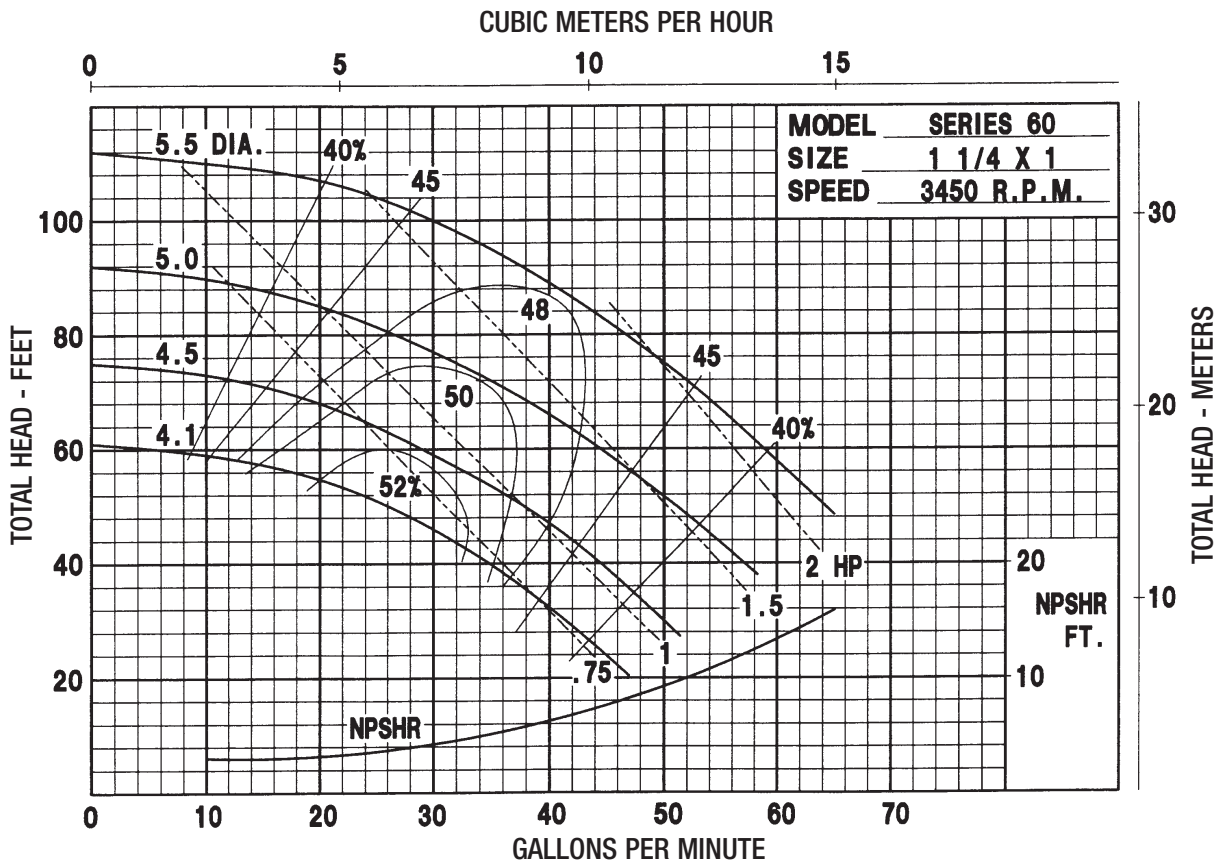

Series 80 Pump Performance Curves

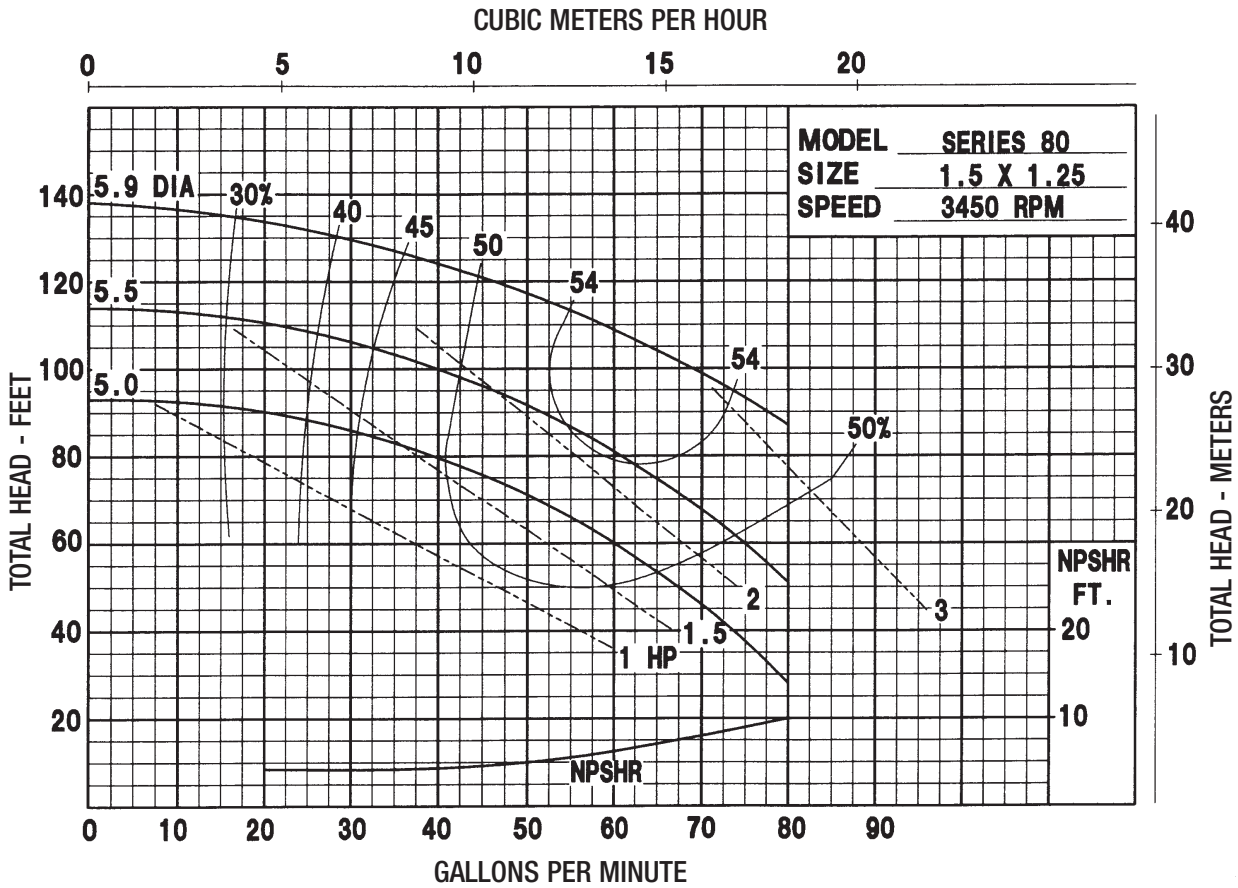

Series 110 Pump Performance Curves

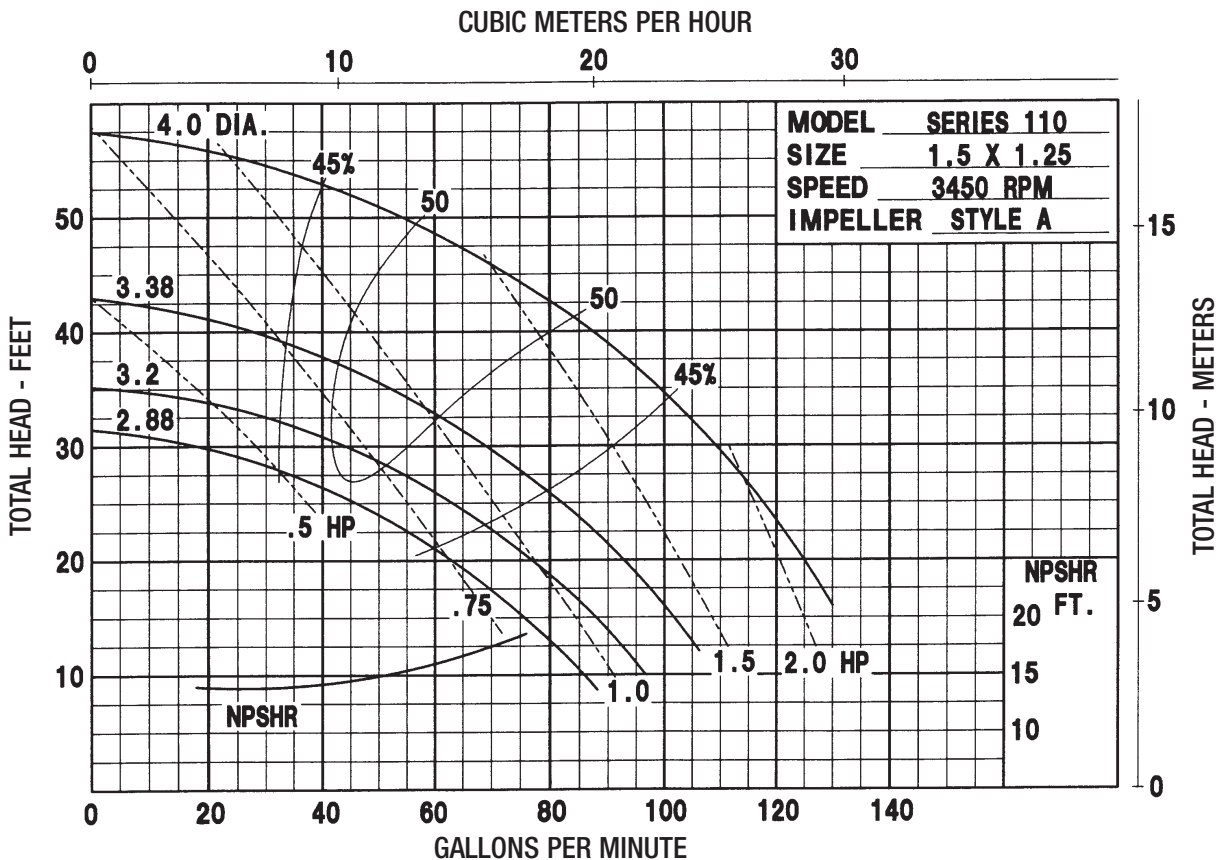

Other Performance Curves Available Upon Request

Series 120 Pump Performance Curves

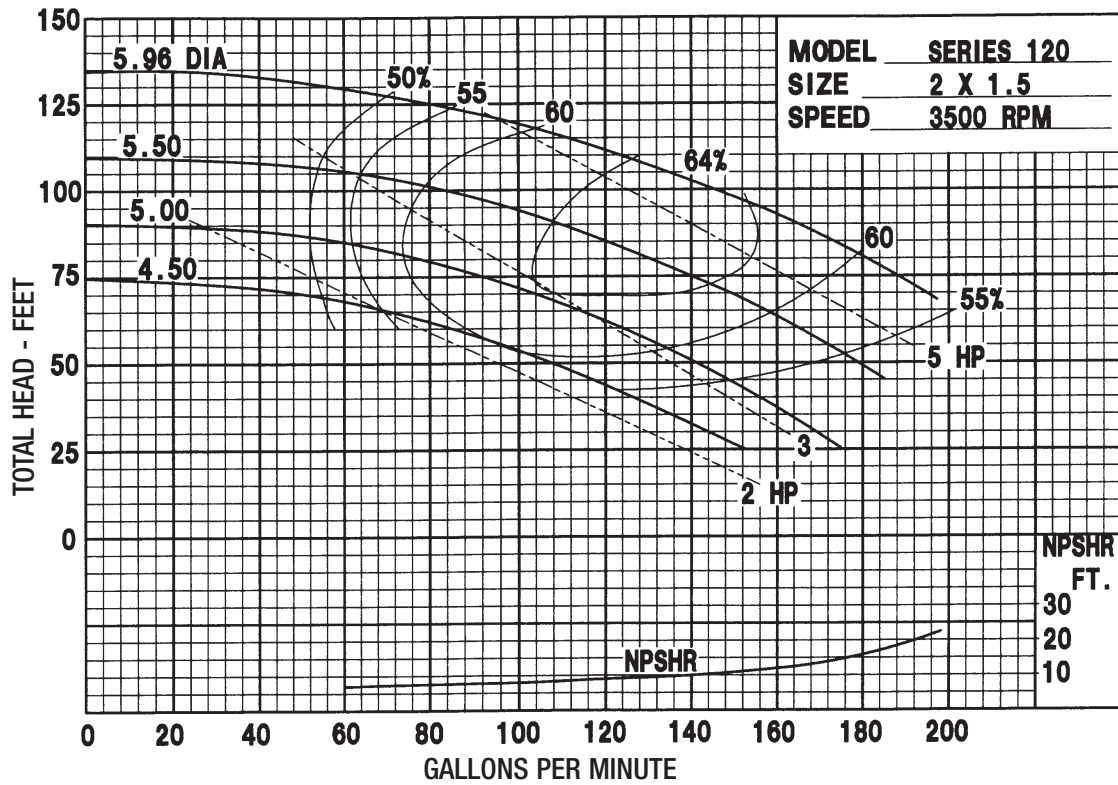

Series 130 Pump Performance Curves

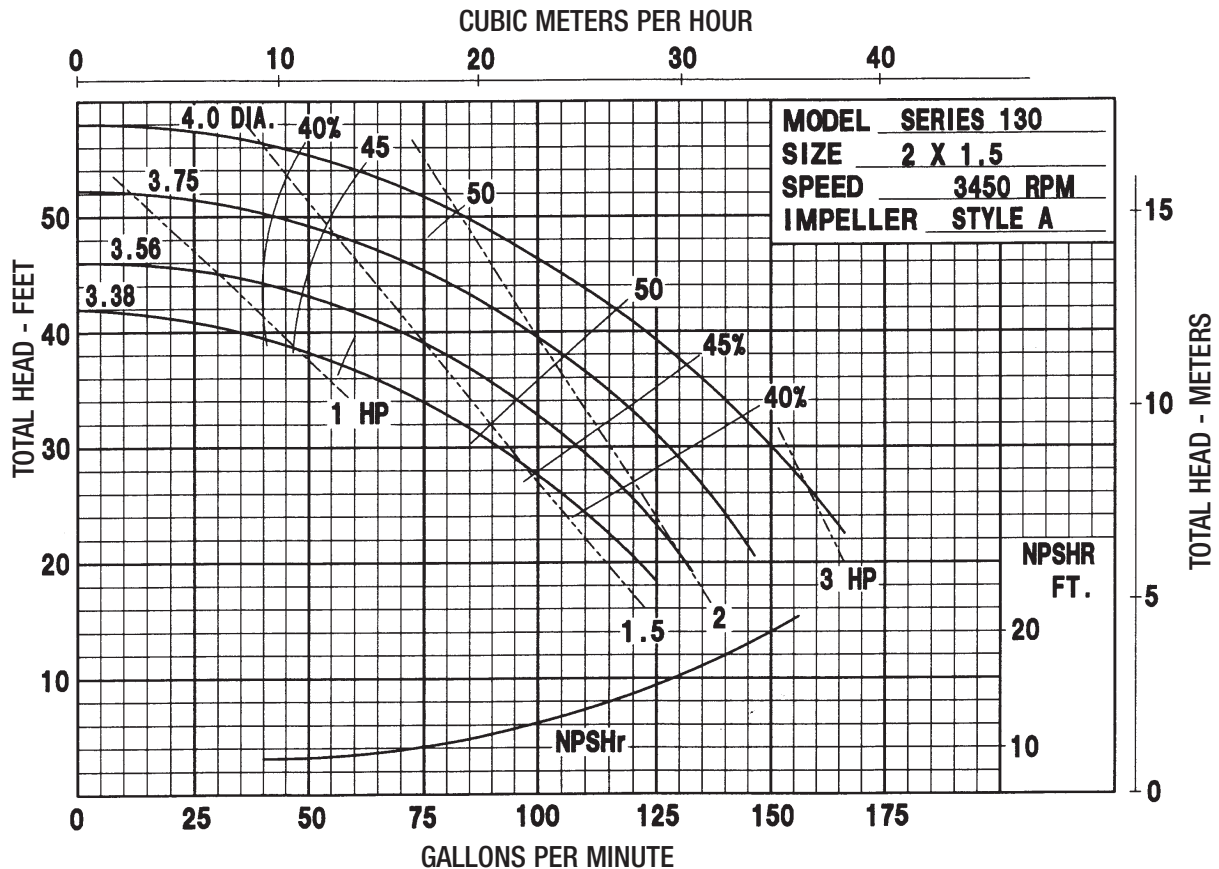

Series 200 Style A Pump Performance Curves

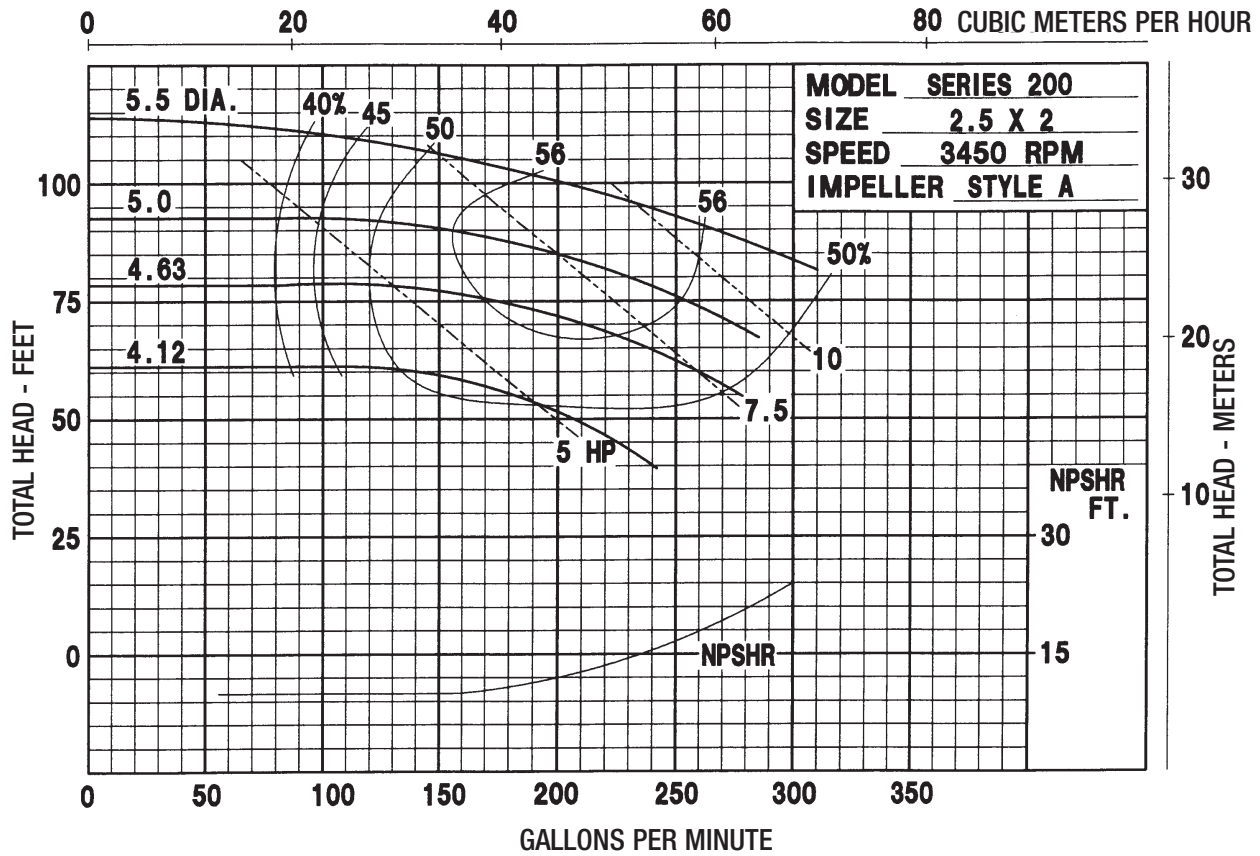

Series 200 Style C Pump Performance Curves

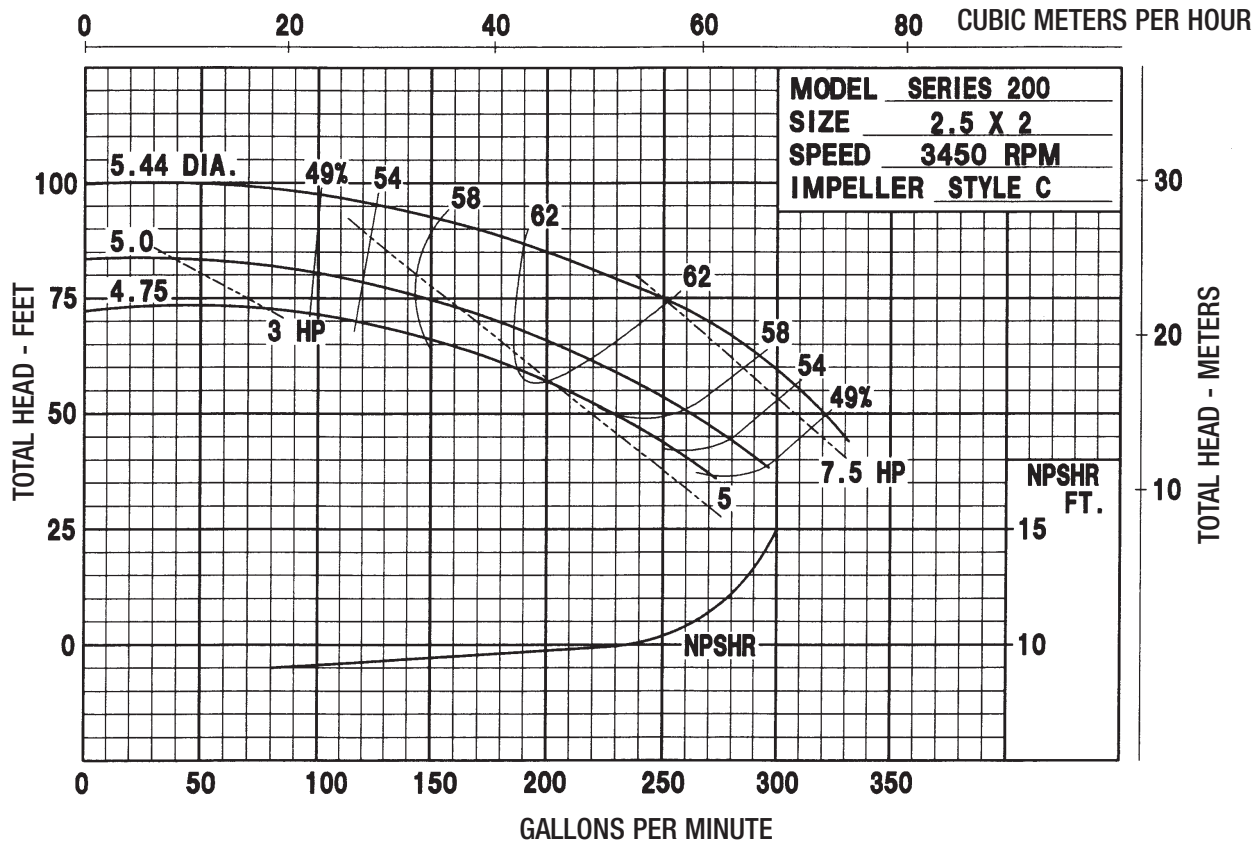

Other Performance Curves Available Upon Request

Series 300 Pump Performance Curves

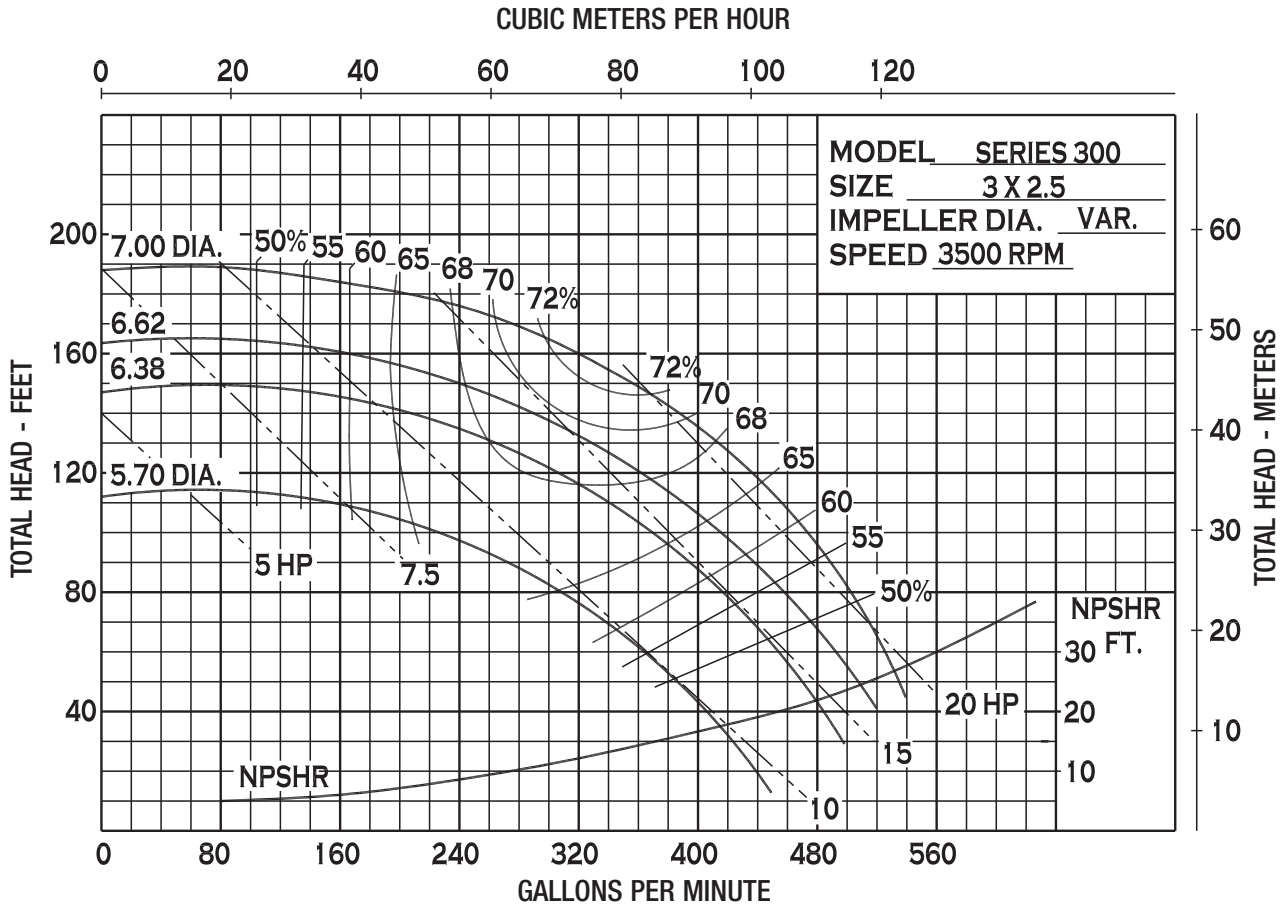

Series 700 Pump Performance Curves

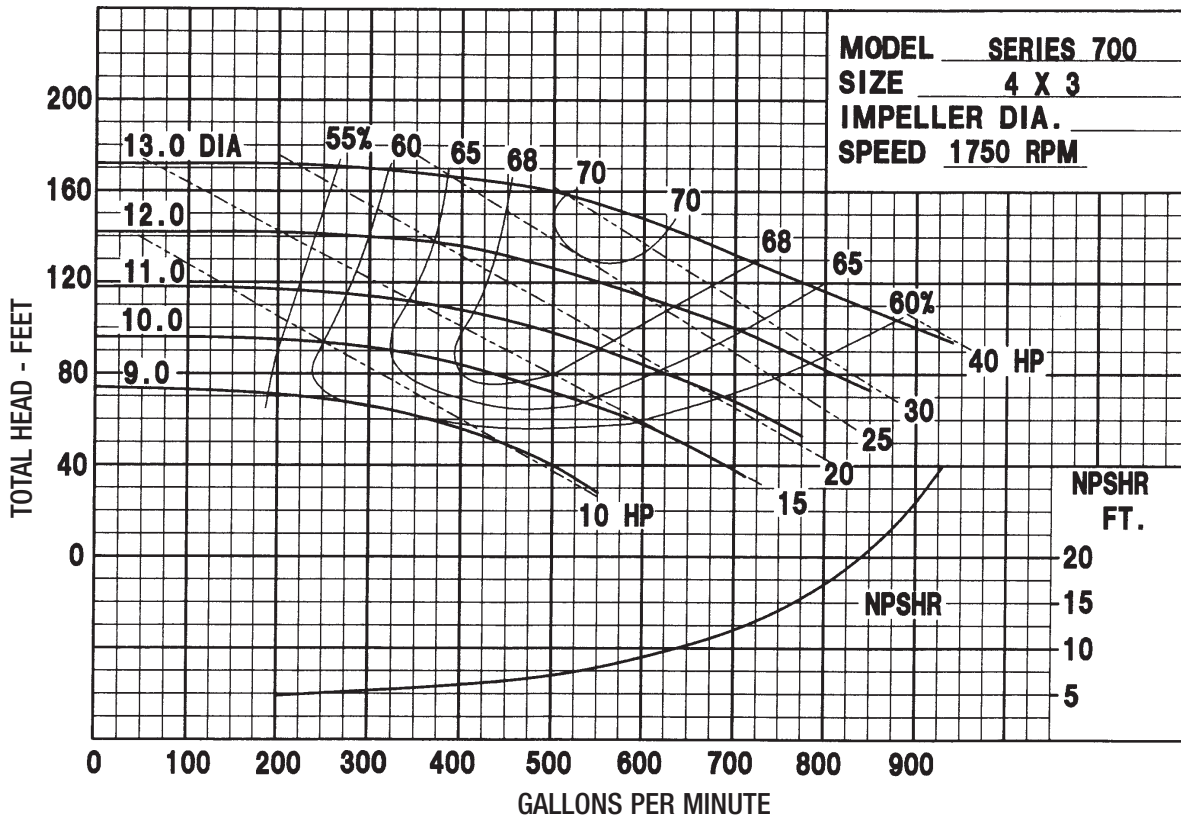

Series 30 Dimensions

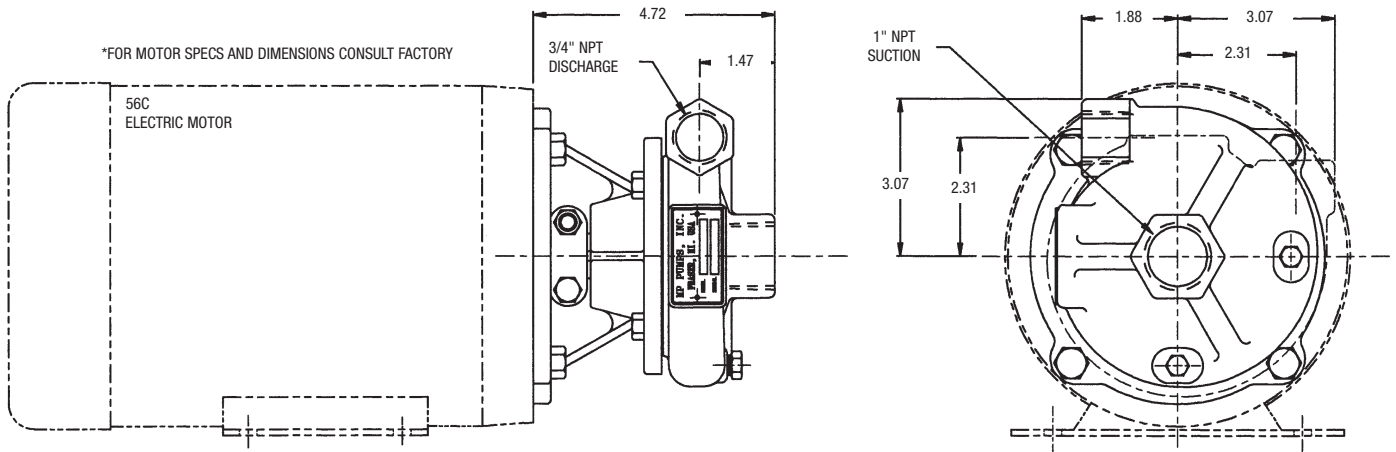

Series 60 Dimensions

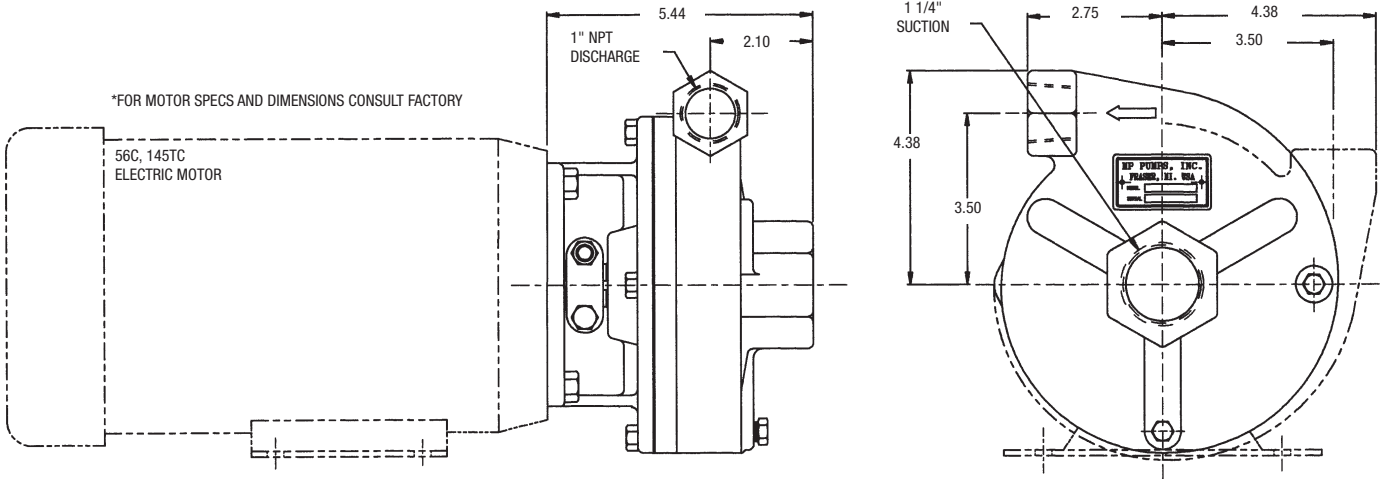

Series 80 Dimensions

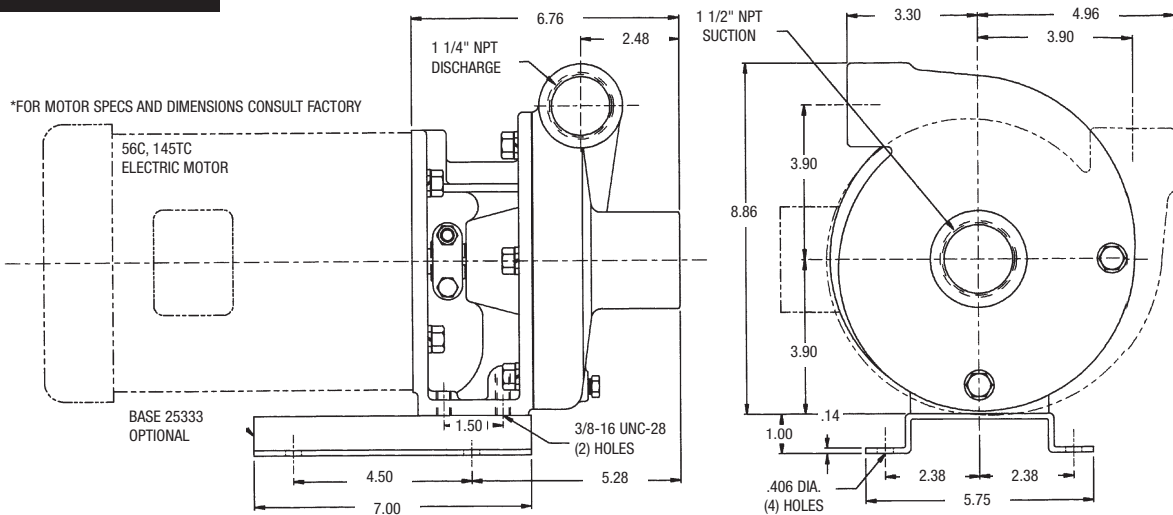

Series 110 Dimensions

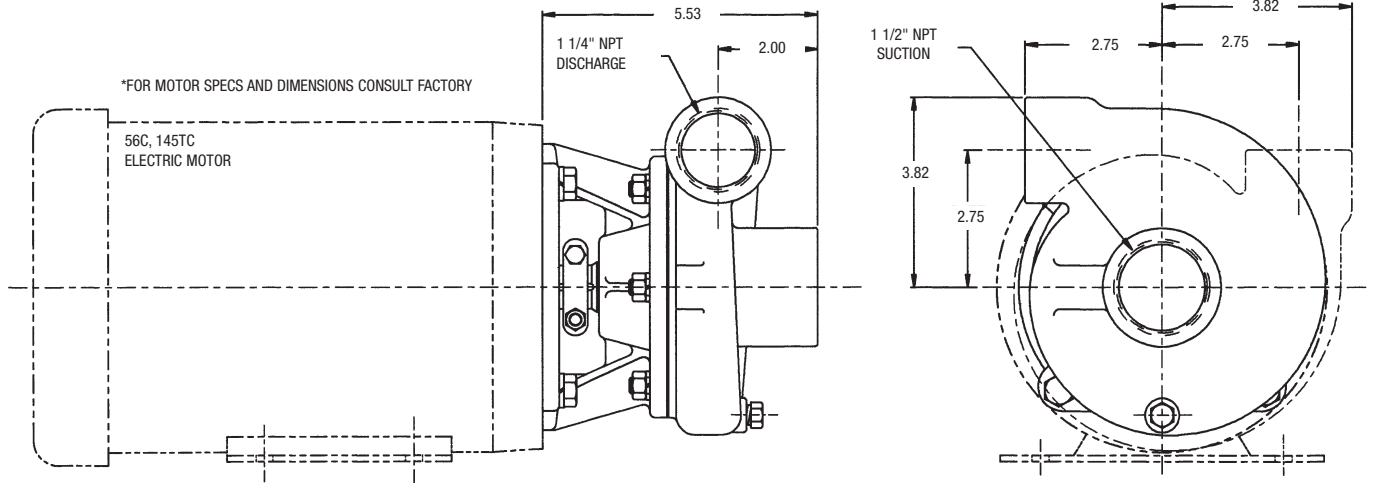

Series 120 Dimensions

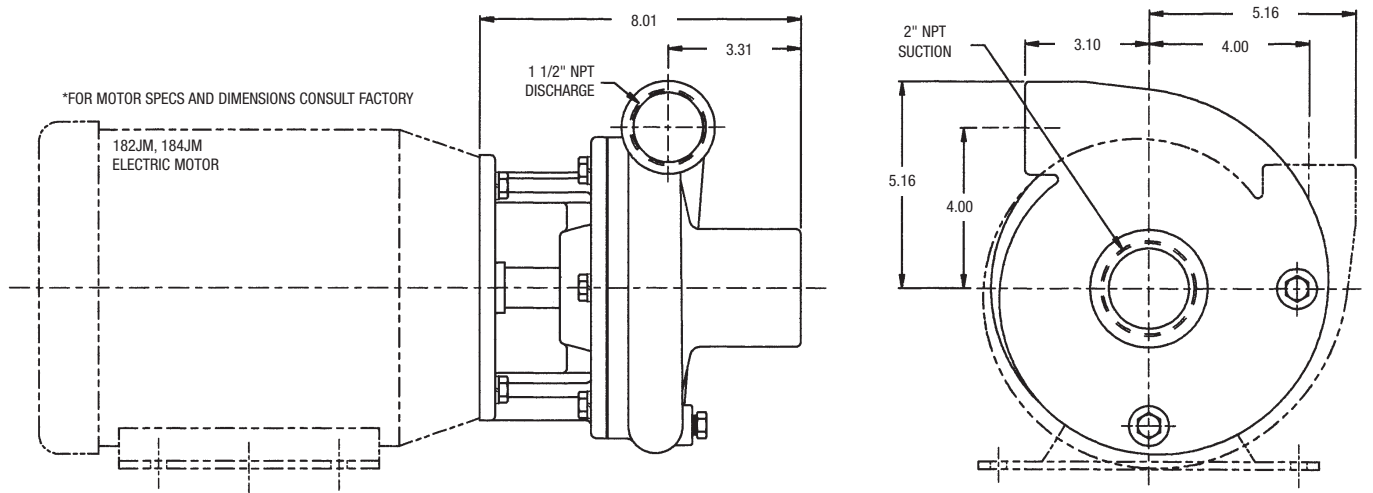

Series 130 Dimensions

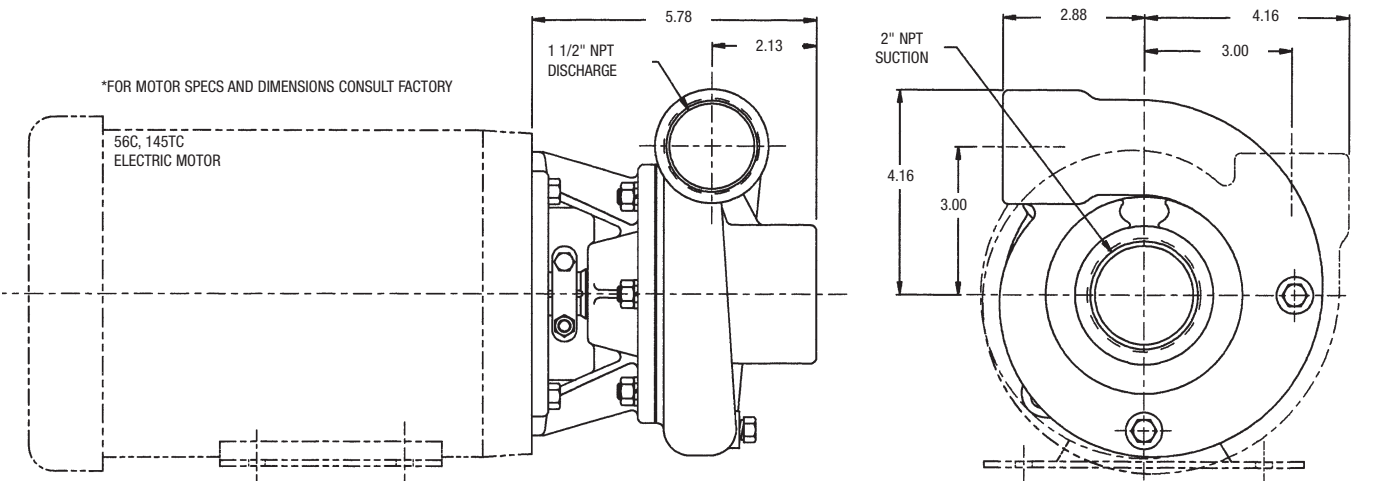

Series 200 Dimensions

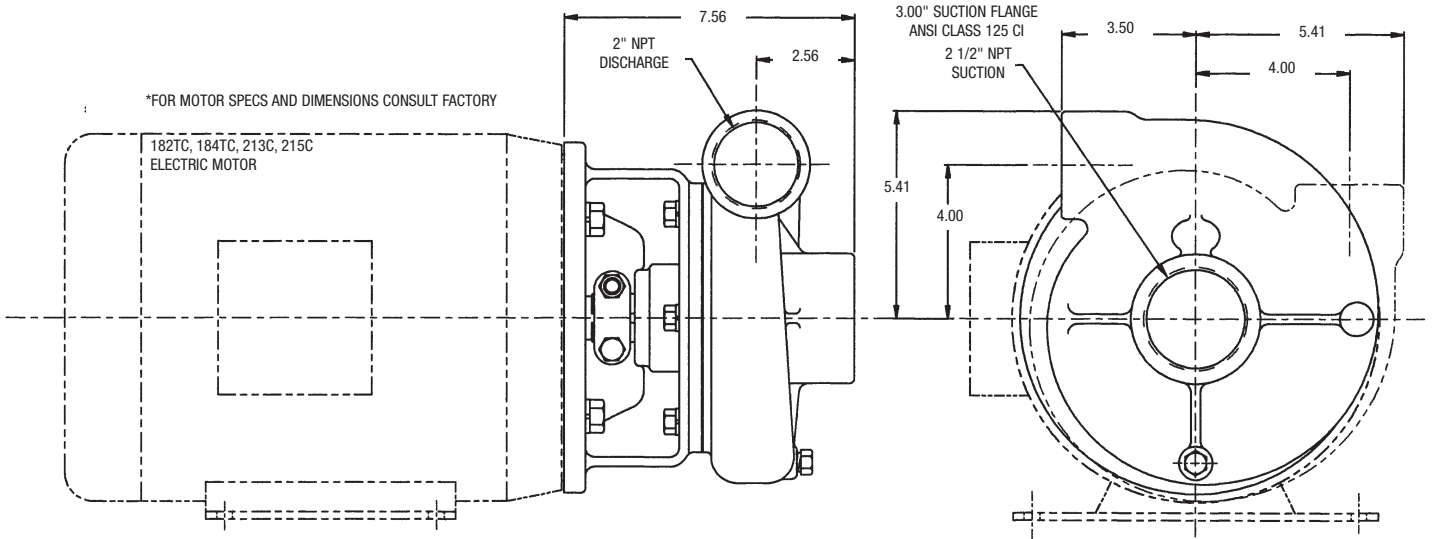

Series 300 Dimensions

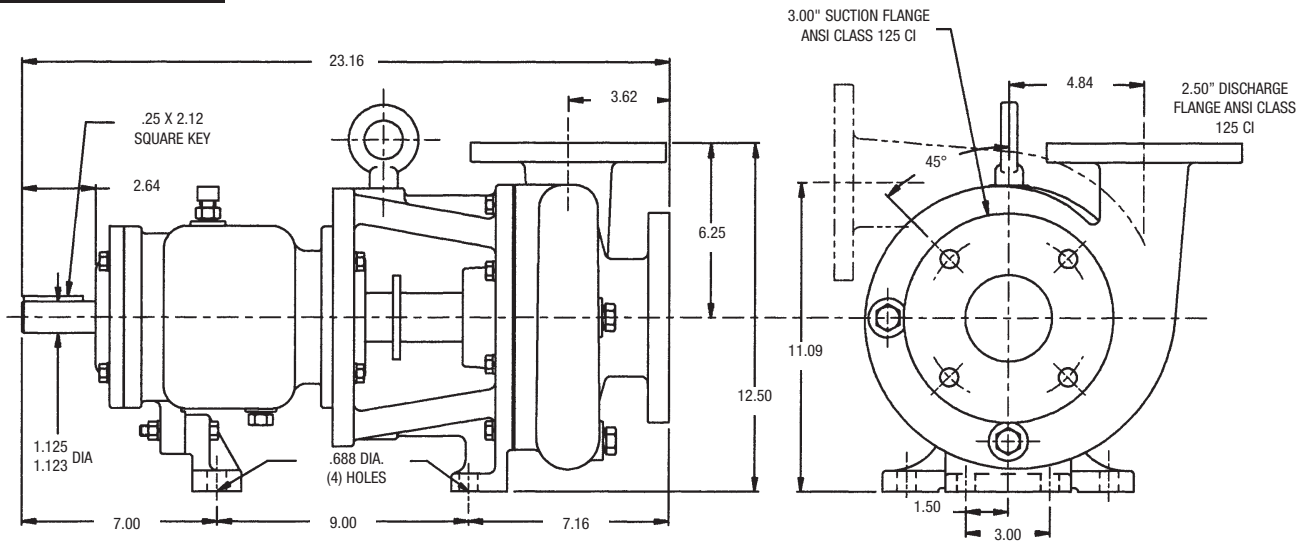

Series 700 Dimensions

